



DISCONTINUED

S19-430EFW, S19-435EFW

Wall-Mount Hand-Held Hose Spray with Dual Sprayheads

- Complies with American National Standard Z358.1
- Acts as an Eye/Face Wash and Hand-Held Spray
- For Eyes and Face or Body Rinsing
- Wall Bracket Included
- Full, One-Year Warranty
- Classified by Underwriters Laboratory Inc. to ANSI Z358.1

Specifications

Quick-access emergency eye and face spray features soft-flow dual sprayheads for flooding large areas as well as eyes only. Handle stays open once valve is squeezed. Stainless steel hose is flexible. Hose bracket for wall hanging included. Hand-held hose sprayhead contains an antimicrobial agent to protect the sprayhead.

- This plumbing fixture is not intended to dispense water for human consumption through drinking or for preparation of food or beverages.
- Drench hoses must provide a controlled flushing fluid flow that is both tepid and non-injurious to the user per ANSI Z358.1. Refer to ANSI Z358.1 for complete regulatory information regarding the performance, installation, maintenance, and training requirements for drench hoses.
- Installer to supply backflow prevention as required by UPC, IPC and/or local plumbing codes. Contact Bradley or visit bradleycorp.com for available options.

Standard Equipment

Eye/Face Dual Sprayheads

Perforated sprayheads are ABS plastic and feature soft-flow dual sprayheads for flooding large areas as well as eyes only. Include protective sprayhead covers. Integral flow control assures safe, steady flow under varying water supply conditions.

Valve

Chrome-plated brass with extended handle stays open once handle is squeezed.

Drench Hose

8' (2438mm) yellow reinforced thermoplastic hose has 3/8" NPT male thread. Burst strength is 450 PSI.

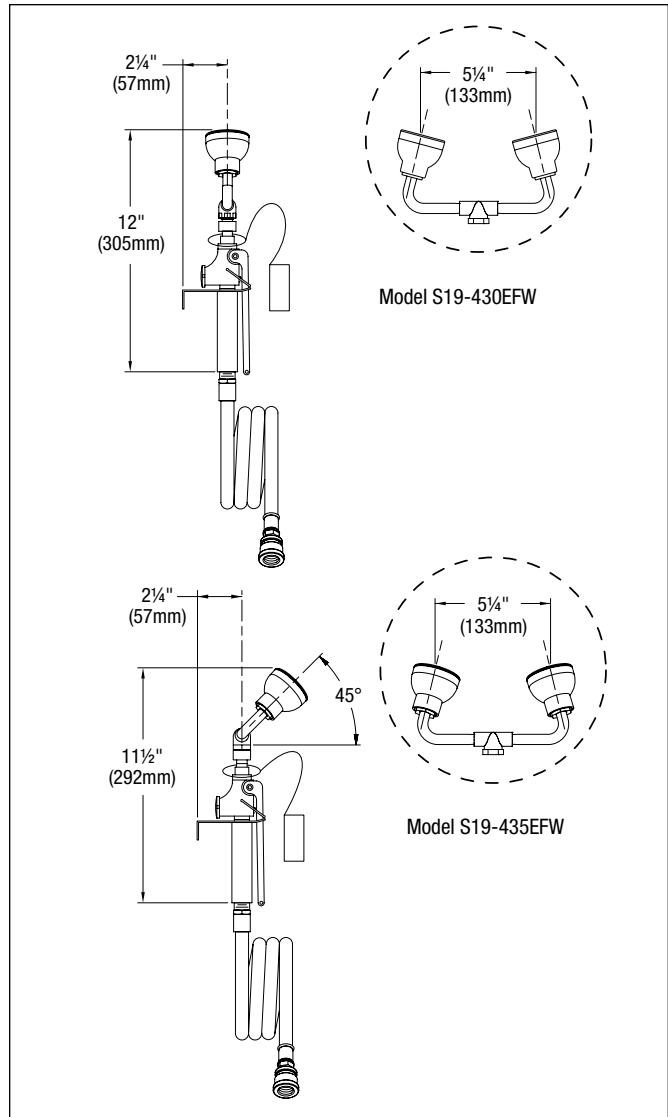

Recommended Option:

Navigator S19-2000 EFX8
Emergency Thermostatic Mixing Valve

Satisfies ANSI Z358.1
tepid water requirements.

Model	Description
S19-430EFW	Wall-Mount Hand-Held Hose Spray with Dual Sprayheads
S19-435EFW	Wall-Mount Hand-Held Hose Spray with Dual Angled Sprayheads
S27-303	Series 7 Dual-Check Backflow Preventer
S45-2309	Series 9 Dual-Check Vacuum Breaker
S45-2310	Series 9D Dual-Check Backflow Preventer