

- Exceeds American National Standard Z358.1 Specifications
- Galvanized Steel Protected with BradTect® Safety Yellow Coating
- Combination Units may be Top-Supplied or Mid-Supplied
- Universal Identification Sign and Inspection Tag Included
- Full, One-Year Warranty
- SpinTec™ showerheads are covered by one or more of the following patents: 8113446; D594,089; D669,555; Reg. Comm. Des. D001079560-0001. Other patents pending.
- Classified by Underwriters Laboratory Inc. to ANSI Z358.1

Specifications

Combination Drench Shower/Eyewash Unit saves space and fits easily into any work environment. Shower valve operates quickly by a pull rod with a triangular handle. Shower provides a superior washdown with a more even spray pattern. Eyewash operated by a large, highly visible push handle. Safe, steady water flow under varying water supply conditions from 30–90 PSI is assured by integral flow control in the sprayhead assembly. NOTE: The ANSI Z358.1 standard requires an uninterrupted supply of flushing fluid at a minimum 30 PSI flowing pressure.

This plumbing fixture is not intended to dispense water for human consumption through drinking or for preparation of food or beverages.

Standard Equipment

SpinTec™ Showerhead

Standard showerhead is 3.1" (78.7mm) diameter highly visible yellow impact-resistant plastic. SpinTec drench showerhead features integral 22 GPM flow control, conserving water and helping to accurately size your tepid water system.

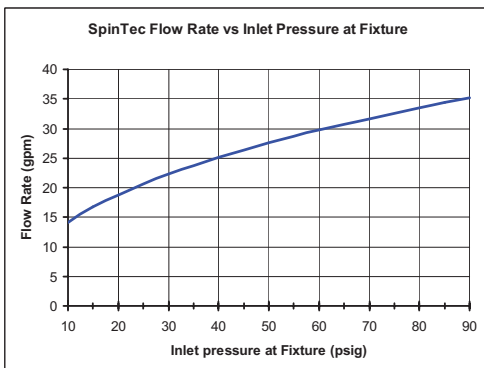

Shower Valve

Chrome-plated brass 1" NPT stay-open ball valve. Operated by a stainless steel rod with triangular handle.

Eye Wash Bowl

10" (254mm) diameter yellow impact-resistant plastic.

Standard Sprayhead Assembly

Chrome-plated brass sprayhead with twin soft-flow eyewash heads and protective sprayhead covers. Safe, steady water flow under varying water supply conditions from 30–90 PSI is assured by integral flow control in the sprayhead assembly.

Eyewash Valve

Chrome-plated brass ½" NPT stay-open ball valve. Hand operated by highly visible safety yellow PVC push handle.

Pipe and Fittings

1¼" galvanized steel with BradTect® safety yellow coating.

Water Supply

1¼" NPT.

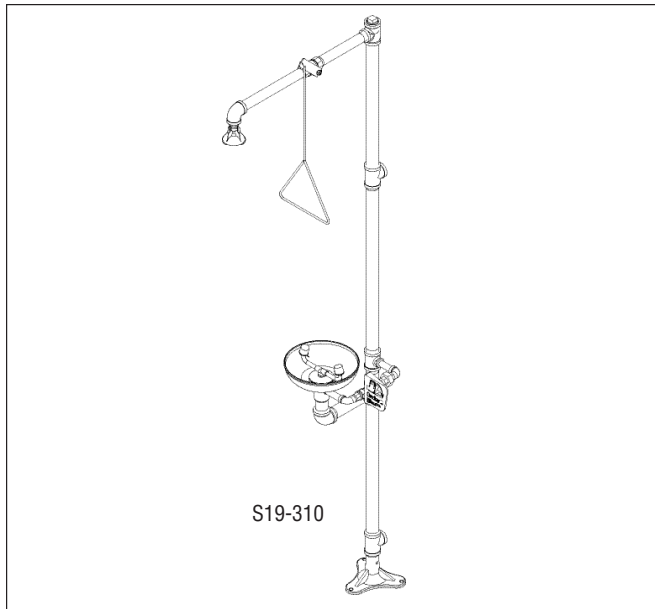

Local codes may require the installation of a backflow prevention valve to complete proper installation. Compliance with local codes is the responsibility of the installer. Valve must be tested annually to verify that it is functioning properly. Backflow prevention valves are not included with the fixture and may be supplied by the contractor or purchased from Bradley Corporation.

Model	Description
<input type="checkbox"/> S19-310	Drench Shower/Eyewash - Plastic Showerhead and Bowl
<input type="checkbox"/> S19-2200	Navigator EFX60 - Emergency Thermostatic Mixing Valve



Recommended Option:

Navigator S19-2200 EFX60
Emergency Thermostatic Mixing Valve

NAVIGATOR



Satisfies ANSI Z358.1
tepid water requirements.

DISCONTINUED



S19-310 Combination Drench Shower/Eyewash Unit

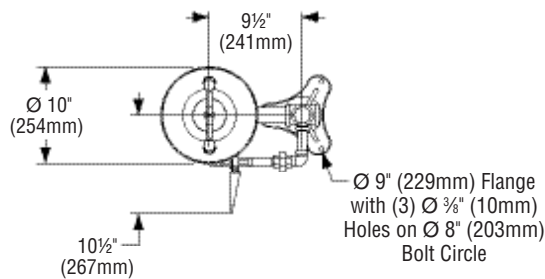
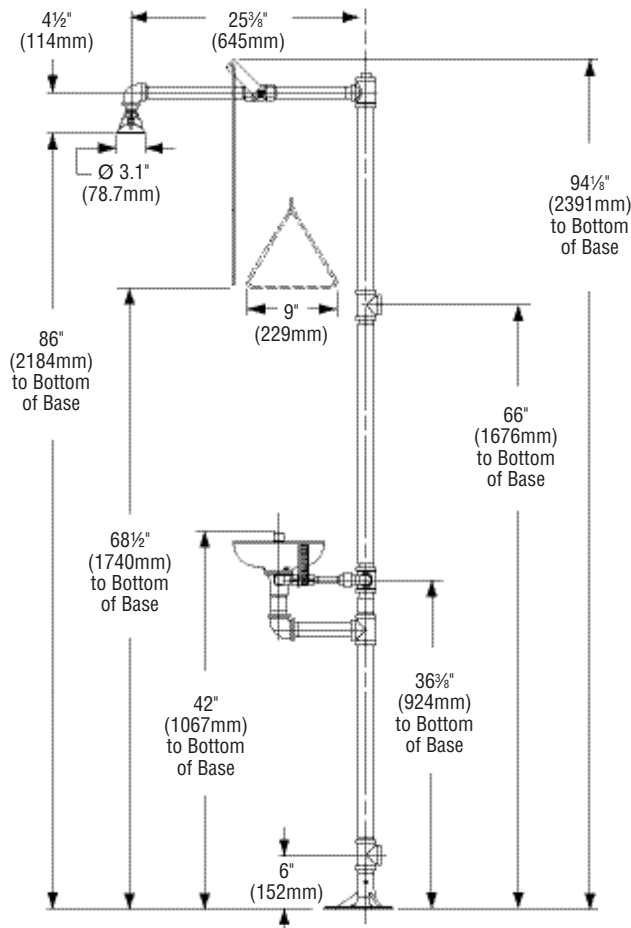

Top View From Bowl



All dimensions assume standard thread engagement. Variations in manufacturing allow for +/- ⅛" (3mm) per threaded joint. To find the tolerance of a dimension, add the number of thread joints in between a dimension and multiply it by ⅛" (3mm).